

# DIN FLANGED BALL VALVES

**REDUCED BORE : DN 15 – 150**

**PN 16 - PN 40**

**SERIES 7000 (716D, 740D)**

The Jamesbury® polymeric-seated flanged ball valves feature a flexible-lip seat design that provides positive bi-directional shut-off for a variety of applications in industries ranging from chemical and petrochemical to refining, pulp and paper, and power.

Polymeric-seated flanged ball valves are available in sizes DN 15 – 150 in both full-bore and reduced-bore designs that fully conform to PED and DIN requirements.

A choice of body, trim, and seat materials is available to suit an extensive range of applications. As an option, valves can be prepared for special services, such as chlorine clean, double block and bleed, oxygen clean, vacuum, NACE MR 0103, or cavity filler.

## Fire-Tite® Valves

Standard body and trim materials for *Fire-Tite* valves are carbon steel with 316 stainless steel trim and all 316 stainless steel. Seat material options include Xtreme® (X) for applications involving chemicals, petrochemicals, acids, caustics, and steam.

## CE Marked

All valves larger than DN25 are CE marked and documented to meet the European Pressure Equipment Directive (PED) 97/23/EC. CE marked products also meet the requirements of BS 5351, including static grounding.

## FEATURES AND BENEFITS

- Xtreme seat provides longer life, industry leading expanded performance boundaries, and greater value.
- Polymeric flexible lip-seat design offers tight shut-off in either direction and extended cycle life with minimum maintenance.
- *Fire-Tite* version with non-metallic seats meets API 607, and ISO 10497 requirements.



- Superior control characteristics, coupled with tight shut-off capabilities, make these valves ideal for a variety of on-off and control applications.
- API 608 compliance to serve refineries and related chemical and petrochemical industries.
- NACE MR0103 compliance available.
- Meets 21 standard and 12 optional industry standards and specifications.
- Face to face dimensions according to ISO 5752.

## NEW FEATURES AND BENEFITS For DN 15 through DN150 Series 7000

- New patented stem seal system is live loaded and engineered to assure long sealing life on sizes up to DN50.
- ISO 5211 Bonnet for global conformity on sizes up to DN50.
- New stainless steel linkage for VPVL, V-Series and ADC-Series actuators has a guided coupling to align topworks during assembly and eliminate side load stress on stem seals for long life, clean environment and reduced maintenance.

## Single-Source Responsibility

- Valves, actuators and accessories may be purchased completely mounted from one source.

## SPECIFICATIONS

### Flow Data

The table at right provides flow coefficients for *Jamesbury* valves covered in this bulletin.  $K_v$  values represent the flow of water at 16°C through the valve in cubic meters per hour at a pressure drop of 1 kg/cm<sup>2</sup>. To convert  $K_v$  to  $C_v$ , divide by .8569.

Valve Size	
DN	$K_v$ Bore
15	8
20	16
25	38
40	107
50	140
80	300
100	470
150	650

### Valve Body Ratings

These are the maximum working pressure ratings of the valve body only. The seat ratings, shown on the next page, determine the practical pressure limitations according to actual service conditions. Test pressures are recommended pressures for hydrostatic test with ball half open.

Temp °C	Maximum Working Pressure, bar			
	PN16		PN40	
	Carbon steel*	316 Stainless steel*	Carbon steel*	316 Stainless steel*
-29 to 38	16	14.7	40	36.8
100	16	12.5	40	31.3
150	15.6	11.4	39.1	28.5
200	15.1	10.6	37.9	26.4
250	14.4	9.8	36	24.7
Test Pressure	24	23	60	56

### Valve Seat Ratings

Seat ratings, indicated by solid lines in the charts on the next page, are based on differential pressure with the valve ball in the fully closed position and refer to seats only. The dotted lines indicate maximum working pressures for *WCB carbon steel* valve bodies. (Maximum working pressures of other body materials are shown in the tables above.) The combination of dotted and solid lines indicates the maximum valve rating at specific pressure and temperature conditions. Valves with *Xtreme* seats can be used in service to -51°C provided that the valve body material is suitable for such a temperature. Carbon steel valves are rated to -29°C.

On saturated steam service, stainless steel trim is recommended at all pressures and is required above 14 bar. See Bulletin B150-1. For more application information on seat materials, refer to Bulletin T140-1.

### Xtreme Performance and Value

*Xtreme* seats provide longer life, expanded performance boundaries, and the greatest possible value. *Xtreme* is a unique material that resulted from a technological breakthrough in our polymer research lab. The material is a fluoro-polymer-based blend proprietary to *Jamesbury* that provides superior quarter-turn performance.

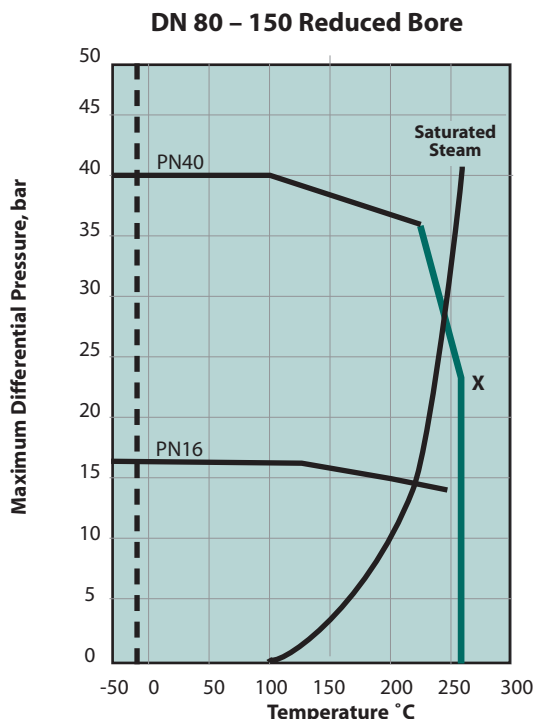
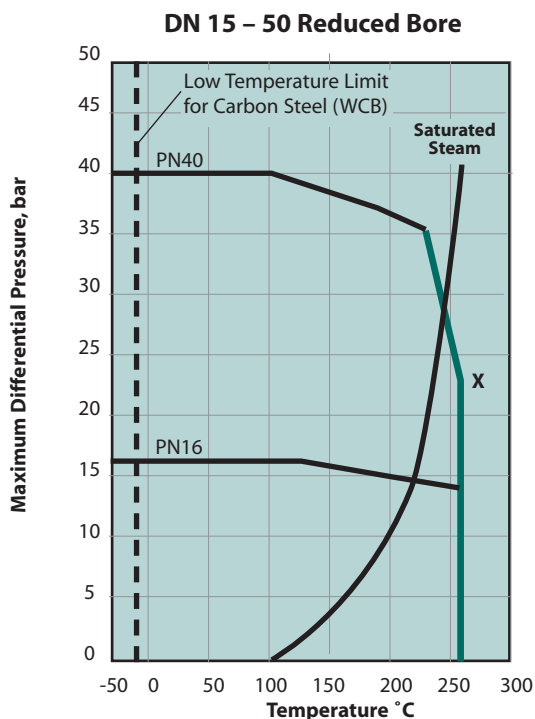

**LEGEND:** X = Xtreme

**Jamesbury brand 'The Ultimate Process Automation Package'  
for VPVL Pneumatic Actuators, V-Series and ADC-Series Electric Actuators**

**DN 15 – 50 Reduced Port Series 7000**

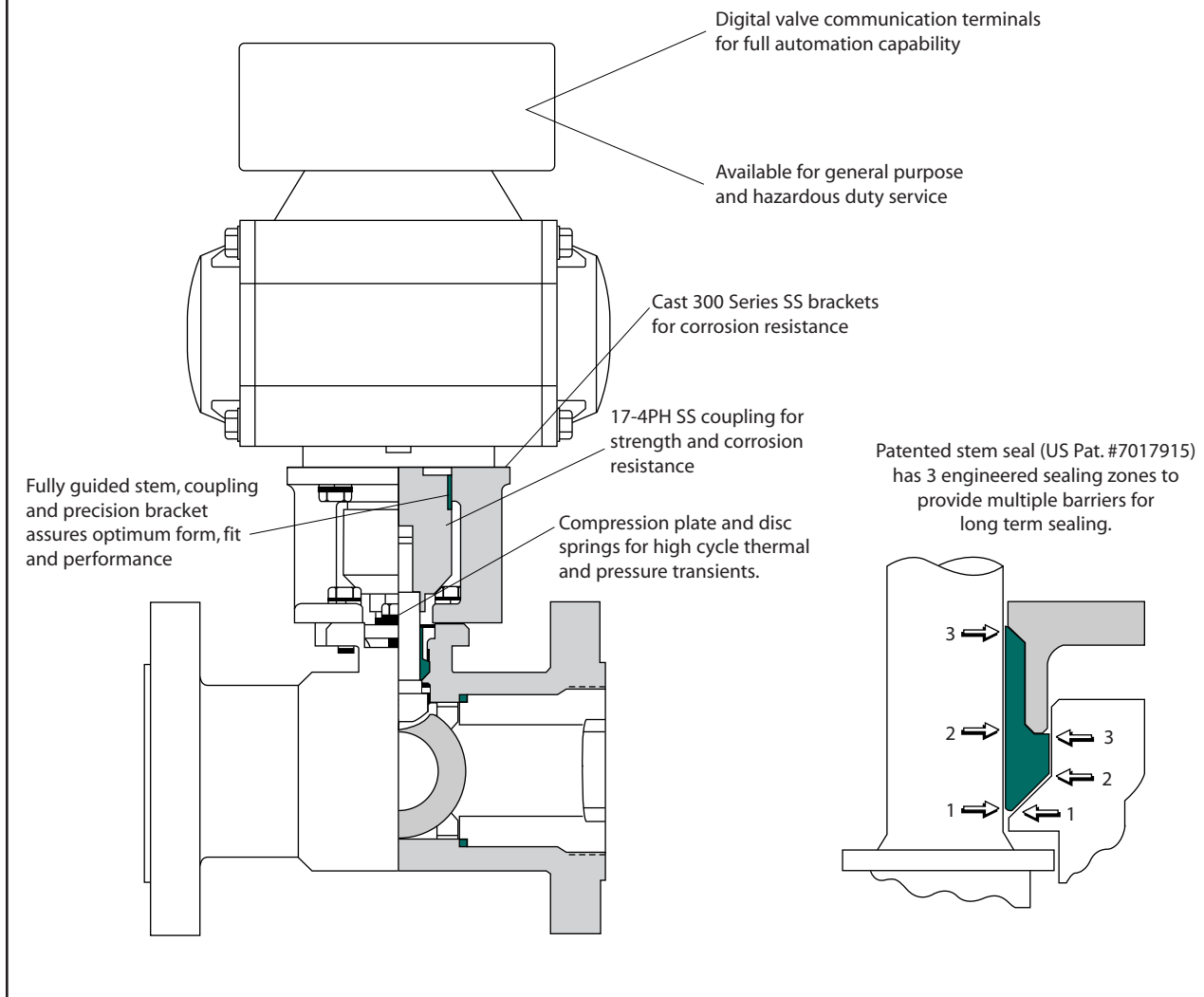

**Automation Performance and Value**

Valves combined with *Jamesbury* actuators offer a total value and performance package. Available with pneumatic Valv-Powr® VPVL actuators, V-Series, ADC-Series, LCU-Series, and LCR-Series electric actuators and with

Stonel® Quartz®, Eclipse®, and Hawkeye® digital monitors or VCTs, the packages have a wide range of applications. Visit our website at: [www.metso.com/automation](http://www.metso.com/automation).

**DIMENSIONS**

**DN15 – 50, Series 716D and 740D**

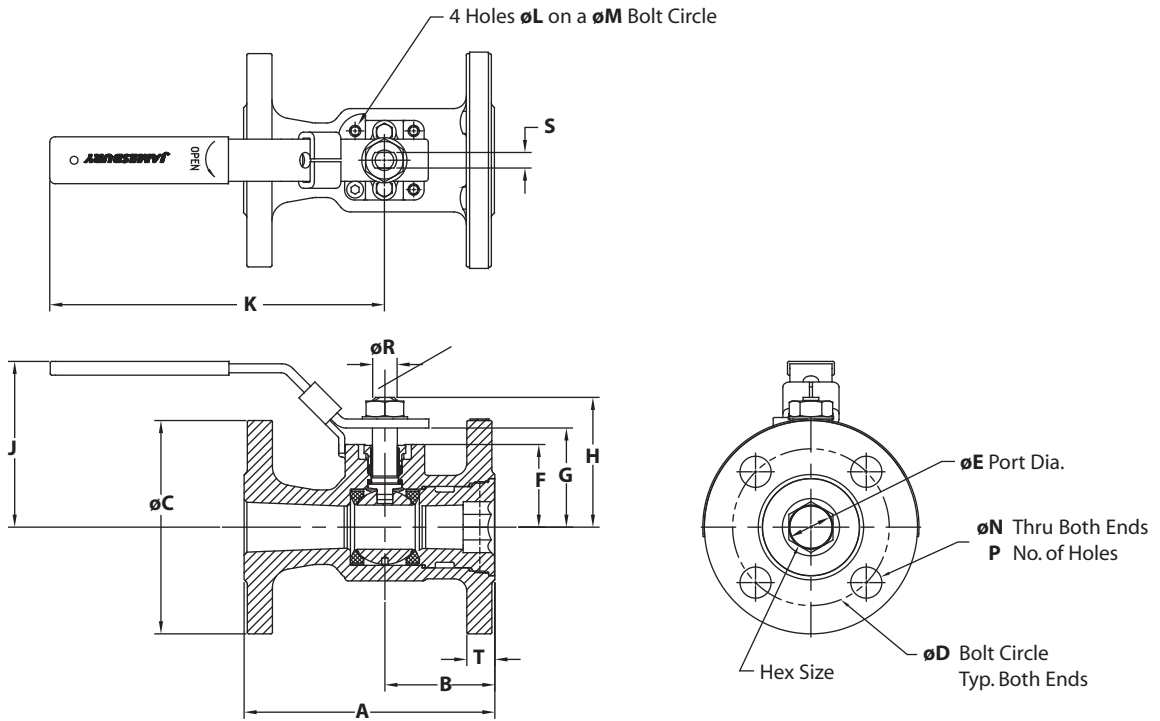

Valve Size DN	Series 716D, PN16 Approximate Dimensions - mm																		ISO Bonnet	Approx Weight kg
	A	B	C	D	E	F	G	H	J	K	L	M	N	P	R	S	T	X		
15	115	49	95	65	13	27	34	41	86	127	M5	36	14	4	8	5	16	13	F03	1.8
20	120	51	105	75	18	31	38	45	89	127	M5	36	14	4	8	5	16	18	F03	2.1
25	125	56	115	85	22	42	52	66	94	165	M5	42	14	4	13	8	18	22	F04	3.7
40	140	67	150	110	32	53	66	84	108	203	M6	50	18	4	16	9	18	32	F05	6.0
50	150	67	165	125	38	57	71	89	113	203	M6	50	18	4	16	9	18	38	F05	7.4

Valve Size DN	Series 740D, PN40 Approximate Dimensions - mm																		ISO Bonnet	Approx Weight kg
	A	B	C	D	E	F	G	H	J	K	L	M	N	P	R	S	T	X		
15	115	49	95	65	13	27	34	41	86	127	M5	36	14	4	8	5	16	13	F03	2.7
20	120	51	105	75	18	31	38	45	89	127	M5	36	14	4	8	5	16	18	F03	2.8
25	125	56	115	85	22	42	52	66	94	165	M5	42	14	4	12	8	18	22	F04	3.8
40	140	67	150	110	32	53	66	84	108	203	M6	50	18	4	16	9	18	32	F05	6.0
50	150	67	165	125	38	57	71	89	113	203	M6	50	18	4	16	9	20	38	F05	9

<b>BILLS OF MATERIALS AND PARTS LIST</b>			
<b>DN 15 – 50, Reduced Port Series 716D and 740D</b>			
<b>Part No.</b>	<b>Part Name</b>	<b>Material</b>	
		<b>Carbon Steel (22)</b>	<b>316 Stainless Steel (36)</b>
1	Body <sup>1</sup>	DIN 1.0619/ A216 Type WCB	DIN 1.4408/ A351 Type CF8M
2	Insert <sup>1</sup>	DIN 1.0619/ A216 Type WCB	DIN 1.4408/ A351 Type CF8M
3	Ball	316 Stainless steel	
4	Stem	316 Stainless steel	
5	Seat	<i>Xtreme</i>	
6	Body Seal	TFM®	
7	Secondary Stem Seal <sup>2</sup>	Graphite <sup>2</sup>	
8	Primary Stem Seal	TFM	
13	Stem Bearing	Filled PTFE	
16	Hex Nut	Carbon steel (zinc plated)	Stainless steel
17	Handle	Carbon steel (zinc plated)	Stainless steel
19	Lock Washer	Carbon steel (zinc plated)	Stainless steel
20	Compression Plate	316 Stainless steel	
25	Socket Cap Screw	Stainless steel	
26	Handle Stop Spacer	Stainless steel	
29	Hex Cap Screw	ISO 3506, A2/A193, Gr. B8	
31	Disc Springs	Inconel	

**Note 1:** When investment castings are used, chemical and physical properties are determined from a master heat in accordance with ASME/ANSI B16.34-2004 Sect. 5.1.3.

**Note 2:** *Fire-Tite* construction only.

### DIMENSIONS

#### DN 80 – 150 Series 716D and 740D (Non-Trunnion)

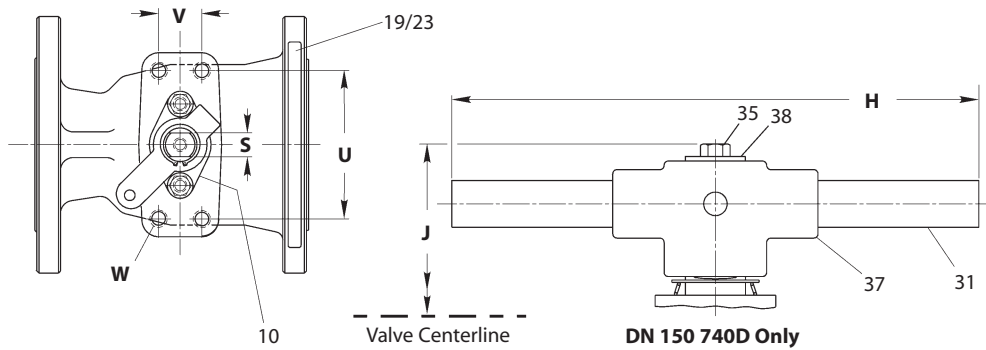

DN 150 740D Only

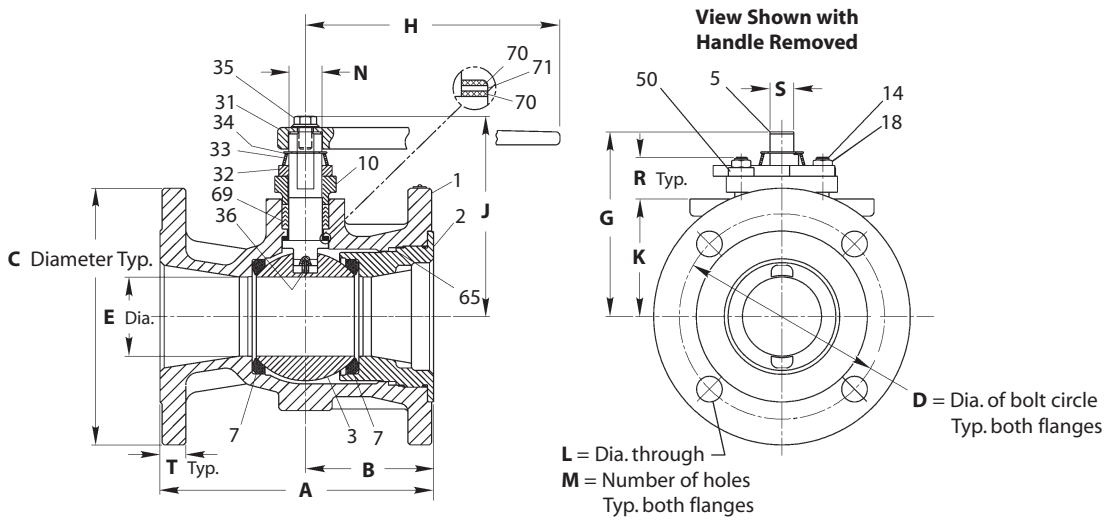

View Shown with Handle Removed

Valve Size DN	Series 716D, PN16 Approximate Dimensions - mm																Weight kg		
	A	B	C	D	E	G	H	J	K	L	M	N	R	S	T	U		V	W
80	180	95	200	160	59	137	356	149	87	18	8	25	32	18	20	110	32	M12	18
100	190	102	220	180	76	150	356	161	100	18	8	25	32	18	20	110	32	M12	26
150	210	108	285	240	102	211	506	223	140	22	8	35	45	25	22	130	32	M12	53

Valve Size DN	Series 740D, PN40 Approximate Dimensions - mm																Weight kg		
	A	B	C	D	E	G	H	J	K	L	M	N	R	S	T	U		V	W
80	180	95	200	160	59	137	356	149	87	18	8	25	32	18	24	110	32	M12	24
100	190	102	235	190	76	191	356	202	119	22	8	35	45	25	24	130	32	M12	39
150	210	111	300	250	102	231	762	255	144	26	8	44	45	32	28	160	40	M16	77

<b>BILLS OF MATERIALS AND PARTS LIST</b>			
<b>DN 80 – 150 Series 716D/740D (Non-Trunnion)</b>			
<b>Part No.</b>	<b>Part Name</b>	<b>Body Material</b>	
		<b>Carbon Steel</b>	<b>316 Stainless Steel</b>
1	Body <sup>1</sup>	DIN 1.0619 / ASTM A216, Gr. WCB	DIN 1.4408 / ASTM A351, Gr. CF8M
2	Insert/Body Cap <sup>1</sup>	DIN 1.0619 / ASTM A216, Gr. WCB	DIN 1.4408 / ASTM A351, Gr. CF8M
3	Ball	316 Stainless steel	
5	Stem	316 Stainless steel	
7	Seat	<i>Xtreme</i>	
10	Compression Plate	Stainless steel	
14	Stud	EN 10269, Gr. 1.7225 / ASTM A193, Gr. B7	ISO 3506, Gr. A2 / ASTM A193, Gr. B8
18	Nut	EN 10269, Gr. 1.1191 / ASTM A194, Gr. 2H	ISO 3506, Gr. A2 / ASTM A194, Gr. 8
19	Identification Tag	Stainless steel	
23	Rivet	Stainless steel	
31	Handle	Ductile Iron	
32	Indicator Stop	Carbon steel	
33	Conical Spring	Inconel	
34	Retainer Ring	Stainless steel	
35	Cap Screw	Carbon steel	
36	Grounding Spring	Inconel	
37	T Handle Adapter	Ductile Iron	
38	Washer	Carbon steel	
50	Stop Bushing	Stainless steel	
65	Body Gasket	PTFE	
69	Packing	molecularly enhanced PTFE	
70	Stem Bearing	Filled PTFE	
71	Secondary Stem Seal <sup>2</sup>	Graphite	

**Note 1:** DN 150 PN40 only.

**Note 2:** *Fire-Tite* construction only.

## ACCESSORIES

### Locking Devices

When safety measures are necessary, a reliable locking plate is available to allow the valve to be padlocked in either the open or closed position. Proper figure numbers are shown in the Accessory Table below.

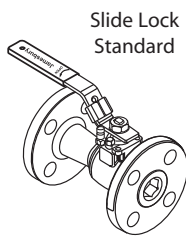

DN 15 - 50 Series 7000

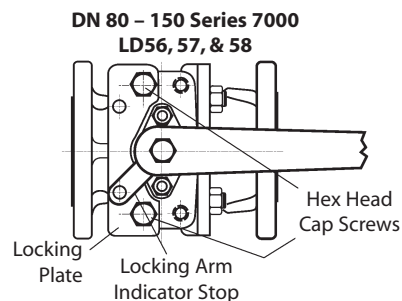

### Bonnet/Stem Extensions SE-096, 097 & 098

102 mm bonnet/stem extensions are available for applications that require insulated pipe, particularly useful for automated products, extension can also be used to prevent interference between actuators and companion pipelines and equipment. They are ideal as extension that require locking lever or locking oval handle capability. Stainless steel construction offers the option of using the extension to complement the carbon steel stem extension (SE-093, 094 & 095) offerings.

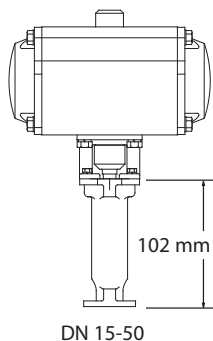

DN 15-50

### Round Handles

Series 7000 ball valves have optional round handles available. To order handles separately, specify the part number shown in the accessories table below.

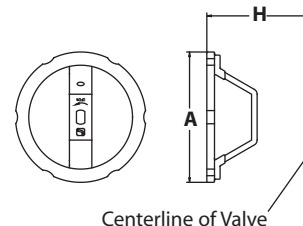

### Oval handles with slide-lock

Optional oval handle saves space and may be padlocked to retain the valve in the open or closed position.

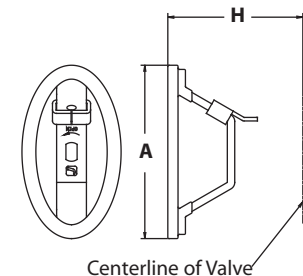

### Stem Extensions SE-093, 094 & 095

A standard 102 mm stem extension is offered for Series 7000 valves for improved accessibility, particularly when used in insulated pipelines. Stem extension kits can be ordered factory-mounted or shipped separately for field mounting.

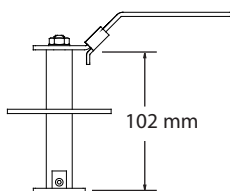

### Stem Extensions SE-60, 61 & 62

A standard 102 mm stem extension is offered for Series 7000 valves for improved accessibility, particularly when used in insulated pipelines. Stem extension kits can be ordered factory-mounted or shipped separately for field mounting.

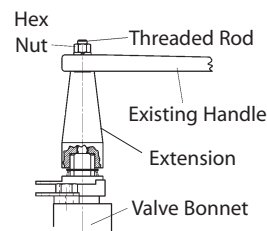

DN 80 - 150 Series 7000

Accessory Table - DN

Valve Size Reduced Bore	Locking Device	Stem Ext.	*Bonnet Ext.	Locking Oval	Round	Round/Oval Handle		Allowable Max. Torque N·m	
						Dimension A	Dimension H	Round	Oval
15	Standard Equipment	SE-093	SE-096	112-0108-30	112-0105-30	101.6	75.2	12	12
20		SE-093	SE-096	112-0108-30	112-0105-30	101.6	79.0	12	12
25		SE-094	SE-097	112-0109-30	112-0106-30	114.3	94.0	24	24
40		SE-095	SE-098	112-0110-30	112-0107-30	146.0	120.7	34	34
50		SE-095	SE-098	112-0110-30	112-0107-30	146.0	125.5	34	34
80	LD56	SE-60							
100 716D	LD56	SE-60							
100 740D	LD57	SE-61							
150 716D	LD57	SE-61							
150 740D	LD58	SE-62							
						NA			



### VALVE TORQUE DATA

Use these torque charts as a guide for actuator selection. Additional requirements may be imposed by media characteristics, trim, and frequency of valve operation. For clean lubricating fluid service, required torque for *Xtreme* (X) and filled PTFE (M) seated valves only may be reduced 20% when the valve is equipped with corrosion resistant trim. For difficult services such as slurries and semi-solids, and for oxygen, increase values by 50%. If in doubt, err on the side of safety by using a larger actuator than would normally be selected.

Valves requiring increased stem seal performance should use E-Pak®. Refer to bulletin B115-4. *E-Pak* valves require an increase in operating torque.

Torque output values and actuator selection tables for the different types of *Jamesbury* brand actuators are contained in the bulletins listed below.

Manual Gear Actuators	A100-1
B-Series Piston Actuators	6B20
Quadra-Powr® X Spring Diaphragm Rotary Actuators	A110-4
<i>Valv-Powr</i> Series VPVL	A111-5
VPVL Stainless Steel	A111-4
V-Series Electric Actuators	A200-1
ADC-Electric Actuators	A201-1
LCU-Series Electric Actuators	A202-1
LCR-Series Electric Actuators	A203-1

#### Valve Torque Data

##### *Xtreme* (X) Seated Valves

DIN 7000 Series, Reduced Bore, DN15 – DN50  
Torque - *Xtreme* Seats

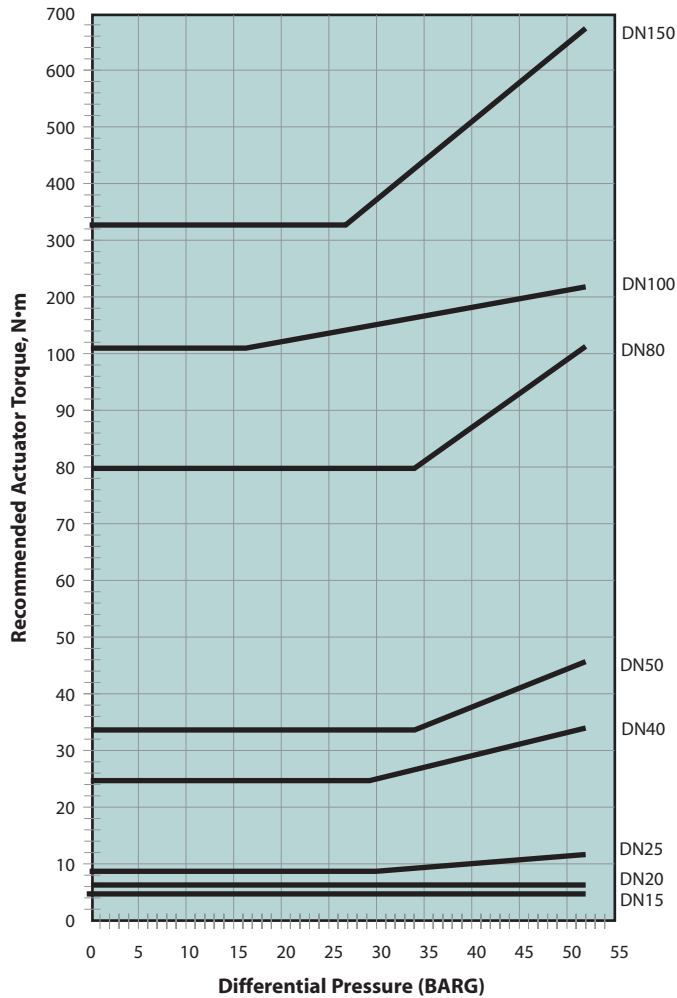

## HOW TO ORDER

**EXAMPLE:** A DN50, PN40 valve (740D) in *Fire-Tite* design with raised-face flanges (31), carbon steel body (22), and 316 stainless steel trim (36), with *Xtreme* seats (XTZ) and molecularly enhanced PTFE stem seals is written: 50 740D-31-2236XTZ1.

1	2	3	—	4	—	5	6	7	8
50	740D	-		31		22	36	XTZ	1

1	Size
15	DN 15
20	DN 20
25	DN 25
40	DN 40
50	DN 50
80	DN 80
100	DN 100
150	DN 150

2	Valve Series & Style	Size Range
<b>716D</b>	Reduced Bore PN16	DN15 – 150
<b>740D</b>	Reduced Bore PN40	DN15 – 150

3	Special Construction
—	Standard (no entry)
<b>C</b>	Chlorine
<b>N</b>	NACE MR0103
<b>O</b>	Oxygen

4	End Connection Construction	Size Range
<b>11</b>	Raised Face Non- <i>Fire-Tite</i> Non-Trunnion	DN 15 – 150 Reduced Bore
<b>31</b>	Raised Face <i>Fire-Tite</i> Non-Trunnion	DN 15 – 150 Reduced Bore

5	Body Material*	Size Range
<b>22</b>	DIN 1.0619/A216 Gr.WCB	All
<b>36</b>	DIN 1.4408/A351 Gr.CF8M	All

\*Other materials available on application

6	Ball & Stem Materials*	Size Range
<b>36</b>	316 Stainless Steel	All
<b>71</b>	Monel	All
<b>00</b>	Same as body	All (Carbon steel not available)

\*Other materials available on application

7	Seat / Body Seal / Stem Seal Material
<b>XTZ</b>	<i>Xtreme</i> /PTFE*/TFM

\*Note: TFM on sizes DN 50 and smaller

8	Bolts	Nuts	Application
<b>1*</b>	EN 10269, 1.7225/ ASTM A193 Gr B7	EN 10269 Gr 1.1191/ ASTM A194 Gr 2H	Carbon Steel
<b>2</b>	ISO 3506 A2 ASTM A193 Gr <u>B8</u>	ISO 3506 A2 ASTM A194 Gr <u>8</u>	Stainless Steel

Bolts and nuts for DN50 and smaller valves apply to bonnet hardware only. For DN80 and larger bolts and nuts pertain to bonnet hardware and body and cap fasteners.

\* Stainless bolting standard for DN50 and smaller

**Note 4:** DN 50 and smaller use Monel bonnet hardware for NACE MR0103 compatibility.

## STANDARDS AND SPECIFICATIONS

### The Company

ISO 9001 – 2000 ANSI/150/ASQ Q9001 – 2000  
Pressure Equipment Directive 97/23/EC

### Available Standards

AD2000	Merkblatt
API 598	American Petroleum Institute - Valve Inspection and testing
API 607	American Petroleum Institute - Fire Test for Soft Seated Valves (Division of refining)
API 608	Metal Ball Valves Used in On-Off Service that have Buttwelded or Flanged Ends for Size DN 15 – 50 NPS
ANSI/ASME B16.34	American National Standard - Steel Valves - Flanged and Buttwelded End
ANSI/FCI 70-2-1991	American National Standard - For Control Valve Seat Leakage
ATEX	Atmosphere Explosive
ISO 15848-1	Industrial Valves - Fugitive Emissions - Measurement, Test & Qualification Procedures
ISO 17292	Metal ball valves for petroleum, petrochemical and allied industries
ISO 5211	Industrial Valve — Part turn Actuator attachment
ISO 5752:1982	International Standard for Organization Metal Valves for use in Flanged Piping Systems
ISA 75.02	Valve Sizing Coefficient Cv, Piping Geometry Factor Fp and Pressure Drop Limitation XT
ISA 575.19	Hydrostatic Testing of Control Valves
ISO 5211	Dimensions for Attachment of Actuators/Gear Boxes to Valves (ISO Mounting)
ISO 9000	
MSS-SP-55	Manufacturers Standardization Society - Quality Standards for Steel Castings
MSS-SP-6-1996	Standard Finishes for Contact Faces of Pipe Flanges and Connecting-End Flanges of Valves and Fittings
PED 97/23/EC	Pressure Equipment Directive
97/23/EC	European Pressure Equipment Directive
ISO 5208	Industrial Valves — Pressure Testing of Valves

Subject to change without prior notice.

**Metso Automation Inc.**

**Europe**, Vanha Porvoontie 229, P.O. Box 304, FI-11301 Vantaa, Finland.  
Tel. +358 20 483 150. Fax +358 20 483 151

**North America**, 44 Bowditch Drive, P.O. Box 8044, Shrewsbury, MA 01545, USA.  
Tel. +1 508 852 0200. Fax +1 508 852 8172

**South America**, Av. Independência, 2500- Iporanga, 18087-101, Sorocaba-São Paulo  
Brazil. Tel. +55 15 2102 9700. Fax +55 15 2102 9748/49

**Asia Pacific**, 20 Kallang Avenue, Lobby B, #06-00, PICO Creative Centre, Singapore 339411, Singapore.  
Tel. +65 6511 1011. Fax +65 6250 0830

**China**, 19/F, the Exchange Beijing, No. 118, Jianguo Lu Yi, Chaoyang Dist, 100022 Beijing, China.  
Tel. +86-10-6566-6600. Fax +86-10-6566-2575

**Middle East**, Roundabout 8, Unit AB-07, P.O. Box 17175, Jebel Ali Freezone, Dubai,  
United Arab Emirates. Tel. +971 4 883 6974. Fax +971 4 883 6836

[www.metso.com/valves](http://www.metso.com/valves)

